

High-efficiency full inverter compact outdoor packaged units

MLI 5 - 30 kW

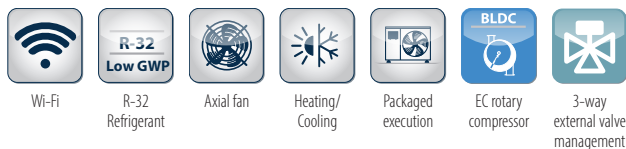
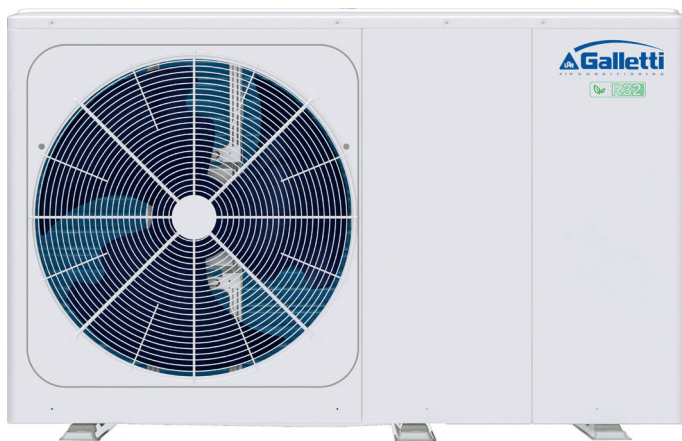

PLUS

- » Twin-rotary compressor driven by an electric EC motor
- » EC hydraulic pump
- » EC axial fan
- » Advanced system management and adjustment strategies
- » Access to tax deductions

High efficiency full inverter heat pumps

MLI is a range of heat pumps consisting of 9 unit sizes and 10 models, equipped with a state-of-the-art inverter compressor capable of efficiently meeting the cooling or thermal power requirements of residential or light commercial buildings.

All models, that access to tax deductions prouded for by actual law, takes full advantage of some of the most innovative HVAC technologies: in fact, all the units are full-inverter and the extended use of electrical motors with permanent magnets driven by inverters with direct current, even for the accessory components – such as fans and water circulators – drastically reduces electrical power consumption and minimizes it under every operating condition, ensuring an energy efficiency level that puts them solidly in class A++ or A+++.

Thanks to the advanced management strategies that have been implemented, the control electronics integrate the functioning of the units' key components, thereby optimizing interaction between the main parts: compressor, fan, and water circulator.

INERTIAL TANK MODULE OPTION

For all sizes, an optional module with an inertial tank is available for installation under the base. The kit includes the storage tank with a capacity of 50 liters when combined with units from 6 to 16 kW, or 140 liters when combined with units from 18 to 30 kW, and the components for hydraulic and mechanical connection. The tank can be used as an in-line storage by closing 2 of the 4 available hydraulic connections with the supplied plugs.

MAIN COMPONENTS



Control unit

The user terminal of the MLI series heat pumps is not a simple remote control, but a sophisticated controller that is capable of extending the basic functions implemented in the unit's electronics. It allows you not only to manage with absolute ease the basic daily functions the machine is intended to provide (on and off, setting the operating mode, instant activation of predefined comfort settings), but also to access advanced programming levels. Customized time slots according to real usage needs and the ability to implement climatic curves on the basis of which to modulate the operation of the unit in order to maximize the overall efficiency of the heating and air-conditioning system, in addition to the ability to manage external equipment such as dehumidifiers, additional hydraulic circulators for primary/secondary loop systems, 3-way valves for the production of domestic hot water and boilers or external backup devices, are just some of the advantages offered to users by this powerful interface. The clear and ergonomic display of the main parameters and the ability to provide in-depth diagnoses of operation are a valuable aid for the maintenance and service operations, it is also possible to remotely control the main functions via smartphone, through the dedicated app.

Heat exchanger

Brazed-welded plate condenser in AISI 316 corrosion resistant austenitic stainless steel, specifically developed to maximise heat exchange coefficients between water and refrigerant.

Fan

The sound levels are especially low thanks to the use of a specially designed fan with airfoil blades that is able to ensure a high air flow rate with limited noise emission.

Compressor

Hermetic twin-rotary compressor driven by a permanent magnet BLDC motor and equipped with a double acoustic insulation is fixed to the base by means of vibration-damping supports.

EXTENDED OPERATING RANGE FOR EACH APPLICATION

MLI series heat pumps were designed to ensure maximum flexibility in every application. Thanks to their extremely wide operating range ensuring the operation even in particularly cold climates and allowing them to produce water up to a maximum of 65 °C and to the advanced adjustment logics provided by the electronic control, they are able to ensure not only winter heating and summer air conditioning, but also the production of thermal energy to be used for domestic hot water production. The high efficiency values that characterize them make it possible, in many cases, to cover the share of renewable energy required by the most recent regulations on limiting energy consumption and to benefit from the tax credits offered by the legislation of many countries that are dedicated to promoting equipment that meets the highest standards.

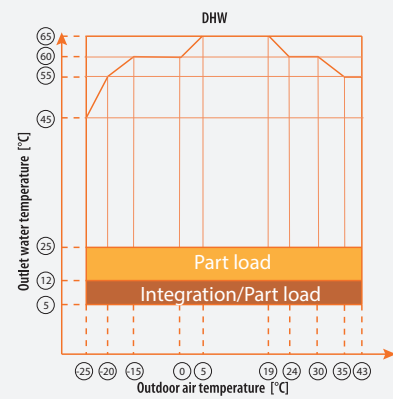
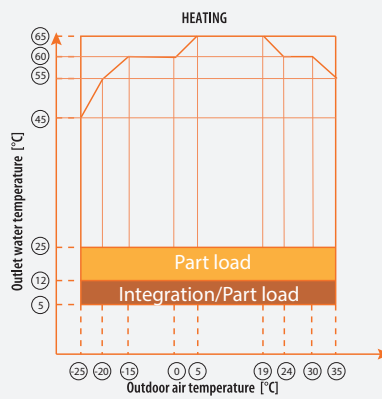
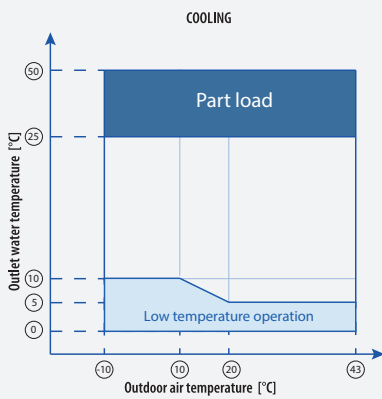

The cooling operating range refers to the dual-fan versions from MLI 018 to MLI 030. For the cooling operating range of the other versions, please refer to the technical manual.

PERFORMANCE AND FUNCTIONALITY ALWAYS ON TOP

The control unit is able to activate an alternative heat generator (boiler or heating element) and employ its operation according to various user-configurable logics in unfavorable weather conditions and particularly high thermal loads, in order to integrate the missing heat capacity or to completely replace heat generation. This feature can also be used during the defrost phases, in order to balance the energy extracted from the heat transfer fluid to melt the ice present on the outside of the heat exchanger, or in the case of machine stoppage due to malfunction or maintenance.

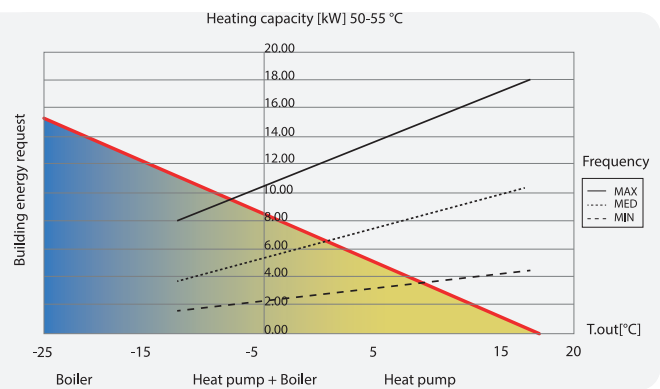

All the models of the MLI range feature extremely compact size and low weight, which allow them to be installed even in environments with high population density and particularly small installation spaces. This is contributed to also by the multi-speed inverter circulator and the expansion tank integrated in the internal hydronic module, thus making superfluous the use of a dedicated technical compartment and in this manner simplifying and speeding up the installation operations. The units' structural metalwork was designed to facilitate maintenance operations and allow easy access to the main internal parts even in the case of limited clearance.

Air Chiller and PDC with low GWP chiller MLI

RATED TECHNICAL DATA

MLI		V-ph-Hz	006M	008M	010M	012M	016	016M
Power supply			230-1-50	230-1-50	230-1-50	230-1-50	400-3N-50	230-1-50
Cooling capacity	(1)(E)	kW	7,00	7,45	8,20	11,5	14,0	14,0
Total power input	(1)(E)	kW	2,33	2,22	2,52	4,18	5,60	5,60
EER	(1)(E)		3,00	3,35	3,25	2,75	2,50	2,50
SEER	(2)(E)		5,34	5,83	5,98	4,89	4,67	4,69
η_{sc}	(2)(E)		209	229	234	194	183	184
Water flow	(1)	l/h	1204	1281	1410	1978	2408	2408
Available pressure head - LP pumps	(1)(E)	kPa	83	82	80	64	49	49
Heating capacity	(3)(E)	kW	6,30	8,10	10,0	12,3	16,0	16,0
Total power input	(3)(E)	kW	1,70	2,10	2,67	3,32	4,57	4,57
COP	(3)(E)		3,70	3,85	3,75	3,70	3,50	3,50
SCOP	(2)(E)		4,95	5,21	5,19	4,81	4,62	4,62
η_{sh}	(2)(E)		195	205	204	189	181	181
Heating energy efficiency class	(4)					A+++		
SCOP	(2)(E)		3,52	3,36	3,49	3,45	3,41	3,41
η_{sh}	(2)(E)		137	131	136	135	133	133
Heating energy efficiency class	(5)					A++		
Water flow	(3)	l/h	1084	1393	1720	2116	2752	2752
Available pressure head - LP pumps	(3)(E)	kPa	85	80	70	64	49	49
Cooling capacity	(6)(E)	kW	6,50	8,30	9,90	12,0	14,2	14,2
Total power input	(6)(E)	kW	1,35	1,64	2,18	3,04	3,93	3,93
EER	(6)(E)		4,80	5,05	4,55	3,95	3,61	3,61
Heating capacity	(7)(E)	kW	6,35	8,40	10,0	12,1	15,9	15,9
Total power input	(7)(E)	kW	1,28	1,63	2,02	2,44	3,53	3,53
COP	(7)(E)		4,95	5,15	4,95	4,95	4,50	4,50
Maximum current absorption		A	18,0	19,0	19,0	30,0	14,0	30,0
Compressors / circuits						1/1		
Expansion vessel volume		dm ³	8	8	8	8	8	8
Sound power level	(8)(E)	dB(A)	58	59	60	65	68	68
Operating weight - unit with pump		kg	126	153	153	175	193	175

(1) Outdoor air temperature 35°C, water temperature 12°C / 7°C (EN14511:2022)

(2) η efficiency values for heating and cooling are respectively calculated by the following formulas: $[\eta = SCOP / 2,5 - F(1) - F(2)]$ e $[\eta = SEER / 2,5 - F(1) - F(2)]$. For further information, please refer to the technical document "ErP 2009/125/EC DIRECTIVE" in the catalogue introducing pages, or to the EN14825:2022 regulation.

(3) Outdoor air temperature dry bulb 7°C / wet bulb 6°C, water temperature 40°C / 45°C (EN14511:2022)

(4) Seasonal energy efficiency class for LOW TEMPERATURE room heating under AVERAGE climatic conditions [EUROPEAN REGULATION No 811/2013. The energy efficiency class of this product is included in the range A+++ → D]

(5) Seasonal energy efficiency class for MEDIUM TEMPERATURE room heating under AVERAGE climatic conditions [EUROPEAN REGULATION No 811/2013. The energy efficiency class of this product is included in the range A+++ → D]

(6) Outdoor air temperature 35°C, water temperature 23°C / 18°C (EN14511:2022)

(7) Outdoor air temperature dry bulb 7°C / wet bulb 6°C, water temperature 30°C / 35°C (EN14511:2022)

(8) Sound power level measured according to ISO 9614

(E) EUROVENT certified data

RATED TECHNICAL DATA

MLI			018	022	026	030
Power supply		V-ph-Hz	400-3N-50			
Cooling capacity	(1)(E)	kW	17,0	21,0	26,0	29,5
Total power input	(1)(E)	kW	5,57	7,12	9,63	11,6
EER	(1)(E)		3,05	2,95	2,70	2,55
SEER	(2)(E)		4,49	4,66	4,70	4,70
η_{sc}	(2)(E)		177	183	185	185
Water flow	(1)	l/h	2924	3612	4472	5074
Available pressure head - LP pumps	(1)(E)	kPa	102	95	78	61
Heating capacity	(3)(E)	kW	18,0	22,0	26,0	30,0
Total power input	(3)(E)	kW	5,14	6,47	8,39	10,3
COP	(3)(E)		3,50	3,40	3,10	2,90
SCOP	(2)(E)		4,60	4,53	4,50	4,19
η_{sh}	(2)(E)		181	178	177	165
Heating energy efficiency class	(4)		A+++	A+++	A+++	A++
SCOP	(2)(E)		3,21	3,22	3,14	3,14
η_{sh}	(2)(E)		125	126	123	123
Heating energy efficiency class	(5)		A++	A++	A+	A+
Water flow	(3)	l/h	3096	3784	4472	5159
Available pressure head - LP pumps	(3)(E)	kPa	100	91	77	58
Cooling capacity	(6)(E)	kW	18,5	23,0	27,0	31,0
Total power input	(6)(E)	kW	3,89	5,00	6,28	7,75
EER	(6)(E)		4,75	4,60	4,30	4,00
Heating capacity	(7)(E)	kW	18,0	22,0	26,0	30,1
Total power input	(7)(E)	kW	3,83	5,00	6,37	7,70
COP	(7)(E)		4,70	4,40	4,08	3,91
Maximum current absorption		A	18,0	21,0	24,0	28,0
Compressors / circuits			1/1			
Expansion vessel volume		dm ³	8	8	8	8
Sound power level	(8)(E)	dB(A)	71	73	75	77
Operating weight - unit with pump		kg	206	206	206	206

(1) Outdoor air temperature 35°C, water temperature 12°C / 7°C (EN14511:2022)

(2) η efficiency values for heating and cooling are respectively calculated by the following formulas: [$\eta = SCOP / 2,5 - F(1) - F(2)$] e [$\eta = SEER / 2,5 - F(1) - F(2)$]. For further information, please refer to the technical document "ErP 2009/125/EC DIRECTIVE" in the catalogue introducing pages, or to the EN14825:2022 regulation.

(3) Outdoor air temperature dry bulb 7°C / wet bulb 6°C, water temperature 40°C / 45°C (EN14511:2022)

(4) Seasonal energy efficiency class for LOW TEMPERATURE room heating under AVERAGE climatic conditions [EUROPEAN REGULATION No 811/2013. The energy efficiency class of this product is included in the range A+++ → D]

(5) Seasonal energy efficiency class for MEDIUM TEMPERATURE room heating under AVERAGE climatic conditions [EUROPEAN REGULATION No 811/2013. The energy efficiency class of this product is included in the range A+++ → D]

(6) Outdoor air temperature 35°C, water temperature 23°C / 18°C (EN14511:2022)

(7) Outdoor air temperature dry bulb 7°C / wet bulb 6°C, water temperature 30°C / 35°C (EN14511:2022)

(8) Sound power level measured according to ISO 9614

(E) EUROVENT certified data

Air Chiller and PDC with low GWP chiller MLI

DIMENSIONAL DRAWINGS

MLI 006

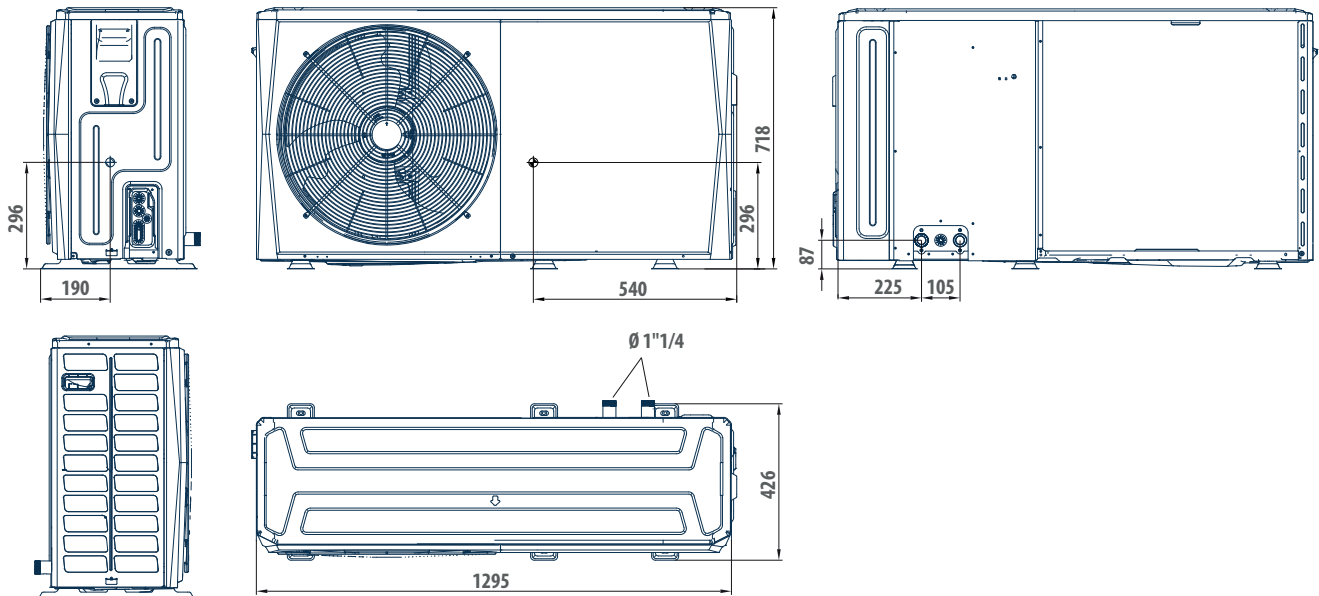

MLI 008-010-012-016

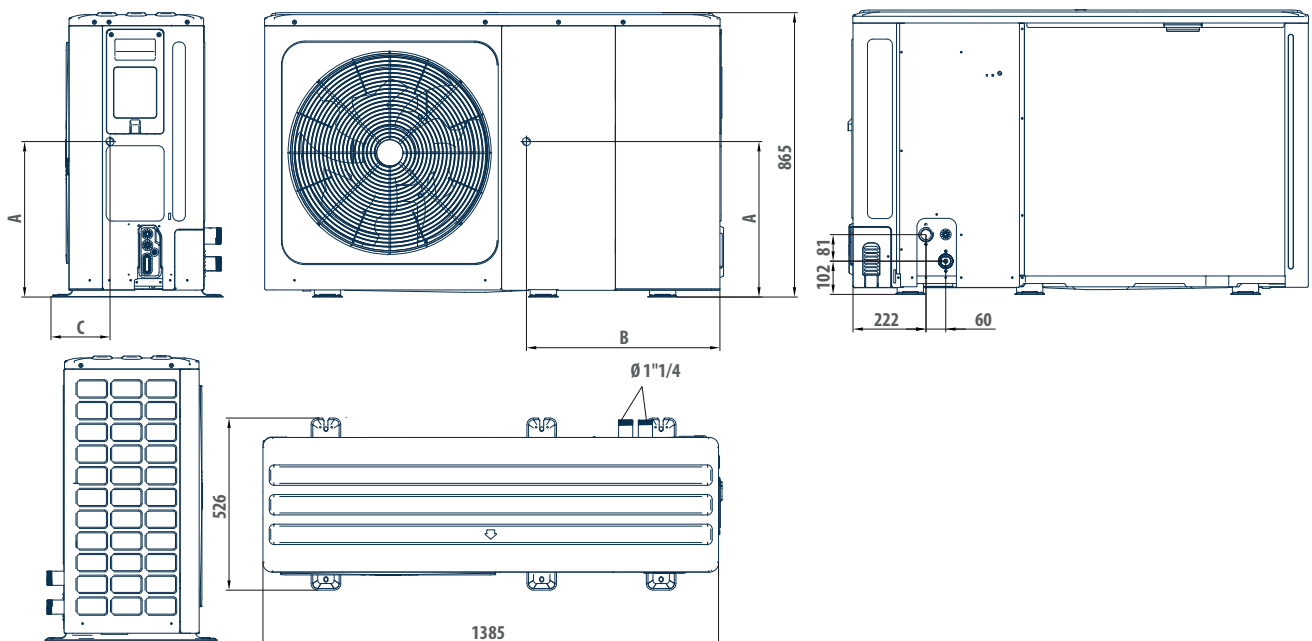

MLI	A mm	B mm	C mm
008M - 010M	330	580	280
012M - 016M	290	605	245
016	200	605	245

DIMENSIONAL DRAWINGS

MLI 018-022-026-030

