

Outdoor packaged unit

PLE 50 - 160 kW



PLUS

- » Refrigerant R454B (GWP=467)
- » High seasonal efficiency values (ErP 2021 compliant)
- » Electronic expansion valve as standard
- » High configurability and wide availability of accessories
- » Availability of standard acoustic execution or in silenced configuration
- » Production of water from -10°C to 55°C
- » Operation limit extension in heating mode due to low T air option
- » Extremely compact dimensions (up to 38 kW/m²)

Air-water unit with high seasonal efficiency and low-GWP refrigerant

PLE is Galletti's new range of air-cooled packaged chillers and heat pumps for outdoor installation featuring R454B refrigerant. R454B is a next generation A2L refrigerant with a GWP of only 467, one of the lowest on the market. This GWP value ensures that the PLE range complies with the gradual reduction of greenhouse gas emissions required by the F-GAS regulation, down to the stricter limits foreseen for 2030.

The range consists of 10 models with cooling capacities from 50 to 160 kW, available as cooling only and reversible heat pump mode.

The range's main strength is its high seasonal efficiency, which is designed to permanently reduce annual energy consumption as well as meet the minimum efficiency requirements established by ErP 2021.

In order to increase the efficiency at partial loads, PLE models are provided with tandem or trio solutions (2 compressors on a single circuit) and equipped with electronic expansion valve as standard.

The use of top quality components at the cutting edge of technology in the cooling, hydraulic, and electrical systems makes PLE chillers state of the art in terms of efficiency, reliability, and operating limits. In fact, the ability to produce water from -10°C to 55°C, and full load operation with external air from -12°C to 46°C.

The range allows high configurability from an acoustic point of view, having a wide range of accessories designed to reduce noise emissions. The advanced control, always present in the whole range, allows a continuous monitoring of the operating parameters, advanced adjustment logics, and connectivity.

PLE heat pumps and water chillers are designed for heating or cooling the water to be used in air-conditioning systems for residential, commercial, or industrial use.

The use of low-GWP refrigerant ensures compliance with the limits established by the F-GAS regulation regarding gases that potentially contribute to global warming (greenhouse gases).

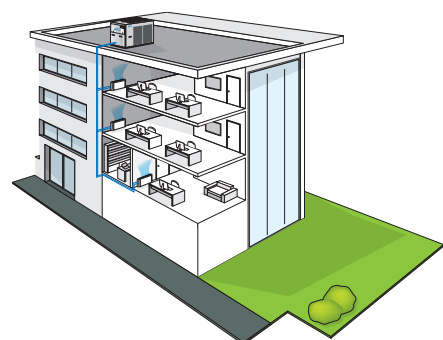

MAIN COMPONENTS

Very low GWP refrigerant

Use of R454B refrigerant with low environmental impact. R454B is a next-generation A2L refrigerant with a GWP of only 467, one of the lowest on the market. This GWP value ensures that the PLE range complies with the gradual reduction of quotas of greenhouse refrigerants in the European market required by the F-GAS regulation, down to the stricter limits foreseen for 2030

Scroll compressors

The scroll-type compressors designed to work with R454B, which can be sound insulated, include internal thermal protection of the windings and are installed on special anti-vibration supports. The scroll-type compressors are equipped with an IDV valve. The IDV intermediate delivery valve technology allows the compressor to avoid losses caused by overcompression and, consequently, the additional work the motor has to perform in partial-load operation, thus saving energy and improving seasonal and partial-load efficiency from 3% to 10%.

Microchannel

The entire Chiller range has microchannel coils as a standard feature. The large heat exchange surface, the absence of a copper-aluminum interface, and the perfect flow of air make it possible to achieve the same performance while reducing the refrigerant charge by up to 40%, with obvious benefits from an ecological point of view. Microchannel coils Galletti always feature surface treatment as a standard feature in order to provide maximum safety, even in harsh environments.

Electronic valve

It is standard on the entire range and offers greater responsiveness during transients. The electronics also manage the synergistic operation of the compressors and the valve, thereby making it possible to vary overheating and maximize efficiency at partial loads.



CONFIGURATOR

The models are completely configurable by selecting the version and the options. To the right is shown an example of configuration.

Version	Field	1	2	3	4	5	6	7	8	9	10	11	12	13
PLE162HS0B		A	1	S	0	E	0	0	2	0	0	G	0	1

To verify the compatibility of the options, use the selection software or the price list.

AVAILABLE VERSIONS

Only cooling versions

- PLE..CS0B Power supply 400V-3N-50Hz
- PLE..CS2B Power supply 400V-3N-50Hz + circuit breaker
- PLE..CS4B Power supply 400V-3-50Hz
- PLE..CS5B Power supply 400V-3-50Hz + circuit breaker

Reversible heat pump versions

- PLE..HS0B Power supply 400V-3N-50Hz
- PLE..HS2B Power supply 400V-3N-50Hz + circuit breaker
- PLE..HS4B Power supply 400V-3-50Hz
- PLE..HS5B Power supply 400V-3-50Hz + circuit breaker

CONFIGURATION OPTIONS

- | | |
|--|--|
| <p>1 Expansion valve</p> <ul style="list-style-type: none"> A Electronic <p>2 Water pump and accessories</p> <ul style="list-style-type: none"> 0 Absent 1 LP pump + expansion vessel 2 LP run and standby double pump + expansion vessel 3 HP pump + expansion vessel 4 HP run and standby double pump + expansion vessel A LP inverter pump + expansion vessel B LP run and standby double inverter pump + expansion vessel C HP inverter pump + expansion vessel D HP run and standby double inverter pump + expansion vessel <p>3 Water buffer tank</p> <ul style="list-style-type: none"> 0 Absent S Selected <p>4 Partial heat recovery</p> <ul style="list-style-type: none"> 0 Absent D Desuperheater with water pump free contact <p>5 Air flow modulation</p> <ul style="list-style-type: none"> A Condensation control with high-head EC electronically controlled fans C Condensation control by phase-cut fans E Condensing control with electronic EC fans <p>6 Antifreezing kit</p> <ul style="list-style-type: none"> 0 Absent E Evaporator P Evaporator and water pump S Evaporator, water pump and water buffer tank <p>7 Acoustic insulation and attenuation</p> <ul style="list-style-type: none"> 0 Absent | <ul style="list-style-type: none"> 3 Compressor soundproof insulations and compressor compartment acoustic insulation <p>8 Refrigerant pipework accessories</p> <ul style="list-style-type: none"> 0 Absent 2 Operation limit extension low T air (Liquid separator in compressor intake + liquid injection) <p>9 Remote control / Serial communication</p> <ul style="list-style-type: none"> 0 Absent 2 RS485 serial board (Carel / Modbus protocol) B BACNET IP / PCOWEB serial board (advanced controller required) G BACNET IP / PCOWEB + SUPERVISOR SOFTWARE (GWeb) S Remote simplified user panel X Remote user panel for advanced controller <p>10 Special coils / Protective treatments</p> <ul style="list-style-type: none"> 0 Copper-aluminum (standard heat pump only) C Cataphoresis treatment on fins and coil carpentry E Microchannel in Long Life Alloy (standard for chiller) I Hydrophilic M Microchannels coil with e-coating treatment P Pre-painted fins with polyester paint R Copper-copper <p>11 Anti vibration shock mounts</p> <ul style="list-style-type: none"> 0 Absent G Rubber anti vibration shock mounts M Spring anti vibration shock mounts <p>12 Outdoor coil trace heater</p> <ul style="list-style-type: none"> 0 Absent 1 Selected <p>13 Onboard controller</p> <ul style="list-style-type: none"> 1 Advanced |
|--|--|

ACCESSORIES

A	Outdoor finned coil heat exchanger protection filters	M	0-10 V signal for external user pump control (on-board pump excluded)
B	Outdoor finned coil heat exchanger protection grille	N	Compressor tandem/trio isolation valves
C	Pair of couplings Victaulic	O	Night-time low-noise
D	ON/OFF status of the compressors	Q	Temperature probe for pump shutdown on the primary circuit
E	Remote control for step capacity limit (advanced controller required)	R	Enabling 2nd set-point / external alarm signaling via digital input
F	Configurable digital alarm board (advanced controller required)	S	Hot-wire electronic flow switch
G	Soft starter	T	Mains power analyzer for monitoring and reducing power consumption
H	Power factor capacitors	U	Unit lifting pipes
I	Refrigerant sensors	V	Set-point modification with 4-20mA signal
L	Water pipes additional insulation		

PLE Chillers and HP with Low GWP refrigerant

WATER CHILLERS RATED TECHNICAL DATA PLE C

PLE			052	062	072	082	092
Power supply		V-ph-Hz	400 / 3+N / 50				
Cooling capacity	(1)(E)	kW	53,0	59,0	66,0	72,0	88,0
Total power input	(1)(E)	kW	17,4	20,1	23,0	26,3	30,2
EER	(1)(E)		3,03	2,92	2,87	2,73	2,91
SEER	(2)(E)		4,42	4,23	4,15	4,12	4,45
Water flow	(1)	l/h	9069	10116	11365	12318	15112
Water pressure drop	(1)(E)	kPa	22	27	27	31	33
Available pressure head - LP pumps	(1)	kPa	164	155	150	140	124
Available pressure head - HP pumps	(1)	kPa	213	204	198	188	183
Maximum current absorption		A	48,0	52,0	58,0	64,0	78,0
Start up current		A	163	170	184	224	254
Startup current with soft starter		A	128	133	144	174	200
Compressors / circuits			2/1				
Buffer tank volume		dm ³	125	125	125	125	190
Sound power level	(3)(E)	dB(A)	80	81	81	81	84
Sound power level, low-noise version	(3)	dB(A)	77	78	78	78	81
Weight without options		kg	462	465	469	476	590
Maximum transport weight		kg	520	523	529	536	682

PLE			102	122	132	142	152
Power supply		V-ph-Hz	400 / 3+N / 50				
Cooling capacity	(1)(E)	kW	97,0	108	122	135	145
Total power input	(1)(E)	kW	34,3	39,9	42,2	49,0	56,1
EER	(1)(E)		2,82	2,72	2,89	2,74	2,59
SEER	(2)(E)		4,25	4,26	4,25	4,18	4,11
Water flow	(1)	l/h	16625	18648	20981	23169	25009
Water pressure drop	(1)(E)	kPa	39	35	43	44	50
Available pressure head - LP pumps	(1)	kPa	115	115	156	148	135
Available pressure head - HP pumps	(1)	kPa	173	174	177	170	157
Maximum current absorption		A	85,0	94,0	105	116	127
Start up current		A	304	304	308	376	376
Startup current with soft starter		A	239	239	243	296	296
Compressors / circuits			2/1				
Buffer tank volume		dm ³	190	190	295	295	295
Sound power level	(3)(E)	dB(A)	84	85	88	88	89
Sound power level, low-noise version	(3)	dB(A)	81	82	85	85	87
Weight without options		kg	591	642	750	808	858
Maximum transport weight		kg	683	733	906	962	1012

(1) Outdoor air temperature 35°C, water temperature 12°C / 7°C (EN14511:2022)

(2) η efficiency values for heating and cooling are respectively calculated by the following formulas: $[\eta = SCOP / 2,5 - F(1) - F(2)]$ e $[\eta = SEER / 2,5 - F(1) - F(2)]$. For further information, please refer to the technical document "ErP 2009/125/EC DIRECTIVE" in the catalogue introducing pages, or to the EN14825:2022 regulation.

(3) Sound power level measured according to ISO 9614

HEAT PUMPS RATED TECHNICAL DATA PLE H

PLE			052	062	072	082	092
Power supply		V-ph-Hz	400 / 3+N / 50				
Cooling capacity	(1)(E)	kW	50,1	54,9	62,5	70,5	83,8
Total power input	(1)(E)	kW	18,5	21,3	24,0	27,0	30,8
EER	(1)(E)		2,71	2,58	2,60	2,61	2,72
SEER	(2)(E)		4,40	4,21	4,11	3,93	4,40
Water flow	(1)	l/h	8624	9446	10758	12140	14418
Water pressure drop	(1)(E)	kPa	21	24	25	31	28
Available pressure head - LP pumps	(1)	kPa	168	160	151	138	129
Available pressure head - HP pumps	(1)	kPa	218	210	200	186	187
Heating capacity	(3)(E)	kW	59,0	66,0	75,0	84,0	99,0
Total power input	(3)(E)	kW	18,3	20,6	23,5	26,0	30,7
COP	(3)(E)		3,21	3,20	3,20	3,24	3,23
SCOP	(2)(E)		3,61	3,66	3,77	3,90	3,61
Heating energy efficiency class	(4)(E)		A+				
Water flow	(3)	l/h	10193	11420	13026	14577	17208
Water pressure drop	(3)(E)	kPa	28	34	35	43	36
Available pressure head - LP pumps	(3)	kPa	160	150	138	118	119
Available pressure head - HP pumps	(3)	kPa	209	199	185	164	177
Maximum current absorption		A	48,0	52,0	58,0	64,0	78,0
Start up current		A	163	170	184	224	254
Startup current with soft starter		A	128	133	144	174	200
Compressors / circuits			2/1				
Buffer tank volume		dm ³	125	125	125	125	190
Sound power level	(5)(E)	dB(A)	80	81	81	81	84
Sound power level, low-noise version	(5)	dB(A)	77	78	78	78	81
Weight without options		kg	502	505	517	532	646
Maximum transport weight		kg	560	563	577	592	739

PLE			102	122	132	142	152
Power supply		V-ph-Hz	400 / 3+N / 50				
Cooling capacity	(1)(E)	kW	92,5	107	120	132	142
Total power input	(1)(E)	kW	36,1	41,0	44,8	49,7	56,3
EER	(1)(E)		2,56	2,61	2,68	2,66	2,53
SEER	(2)(E)		4,02	4,22	4,23	4,15	3,93
Water flow	(1)	l/h	15927	18419	20699	22745	24516
Water pressure drop	(1)(E)	kPa	36	34	42	38	44
Available pressure head - LP pumps	(1)	kPa	116	115	158	156	138
Available pressure head - HP pumps	(1)	kPa	175	173	179	177	160
Heating capacity	(3)(E)	kW	111	125	138	157	172
Total power input	(3)(E)	kW	34,7	39,1	43,1	48,4	53,8
COP	(3)(E)		3,20	3,20	3,21	3,24	3,20
SCOP	(2)(E)		3,61	3,84	3,73	3,79	3,73
Heating energy efficiency class	(4)(E)		A+				
Water flow	(3)	l/h	19221	21658	23996	27204	29845
Water pressure drop	(3)(E)	kPa	51	46	55	51	60
Available pressure head - LP pumps	(3)	kPa	101	96	140	136	111
Available pressure head - HP pumps	(3)	kPa	159	154	162	158	132
Maximum current absorption		A	85,0	94,0	105	116	127
Start up current		A	304	304	308	376	376
Startup current with soft starter		A	239	239	243	296	296
Compressors / circuits			2/1				
Buffer tank volume		dm ³	190	190	295	295	295
Sound power level	(5)(E)	dB(A)	84	85	88	88	89
Sound power level, low-noise version	(5)	dB(A)	81	82	85	85	87
Weight without options		kg	647	711	828	906	956
Maximum transport weight		kg	739	801	983	1059	1109

(1) Outdoor air temperature 35°C, water temperature 12°C / 7°C (EN14511:2022)

(2) η efficiency values for heating and cooling are respectively calculated by the following formulas: [$\eta = SCOP / 2,5 - F(1) - F(2)$] e [$\eta = SEER / 2,5 - F(1) - F(2)$]. For further information, please refer to the technical document "Erp 2009/125/EC DIRECTIVE" in the catalogue introducing pages, or to the EN14825:2022 regulation.

(3) Outdoor air temperature dry bulb 7°C / wet bulb 6°C, water temperature 40°C / 45°C (EN14511:2022)

(4) Seasonal energy efficiency class for LOW TEMPERATURE room heating under AVERAGE climatic conditions [EUROPEAN REGULATION No 811/2013. The energy efficiency class of this product is included in the range A+++ → D]

(5) Sound power level measured according to ISO 9614

(E) EUROVENT certified data

PLE Chillers and HP with Low GWP refrigerant

DIMENSIONAL DRAWINGS

PLE 52-82

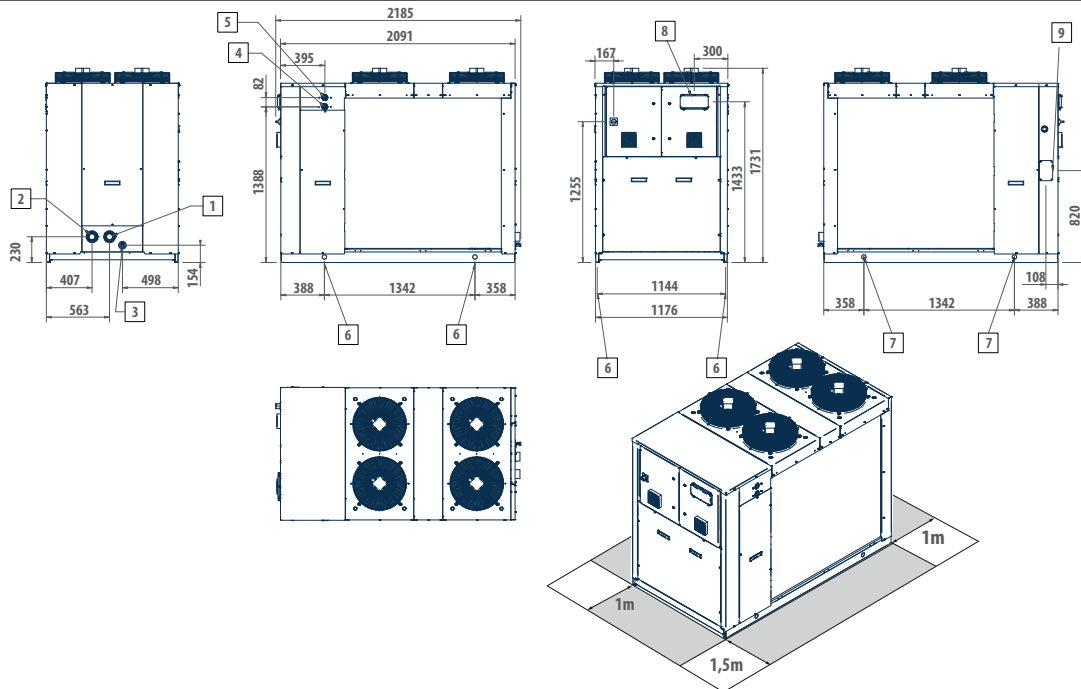

LEGEND

1	Water inlet Victaulic 2"	6	Vibration dampers
2	Water outlet Victaulic 2"	7	Lifting points
3	Water drainage 1/2" F	8	User interface
4	Heat exchanger inlet 1" 1/4 F	9	Power supply input
5	Heat exchanger outlet 1" 1/4 F		

PLE 92-122

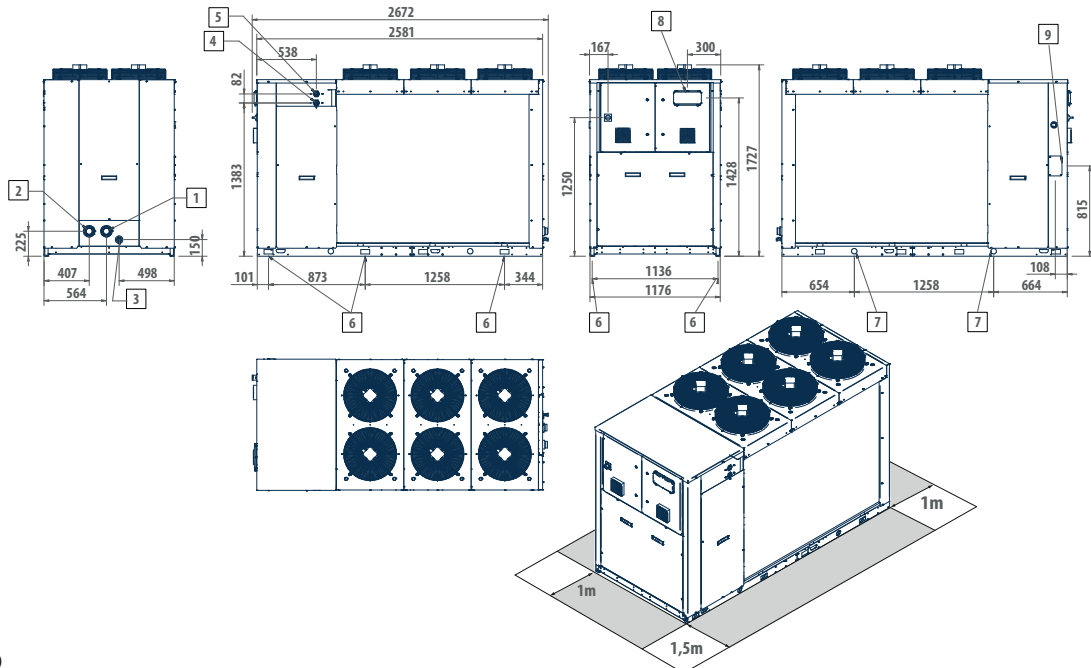

LEGEND

1	Water inlet Victaulic 2"	6	Vibration dampers
2	Water outlet Victaulic 2"	7	Lifting points
3	Water drainage 1/2" F	8	User interface
4	Heat exchanger inlet 1" 1/4 F	9	Power supply input
5	Heat exchanger outlet 1" 1/4 F		

DIMENSIONAL DRAWINGS

PLE 132-152

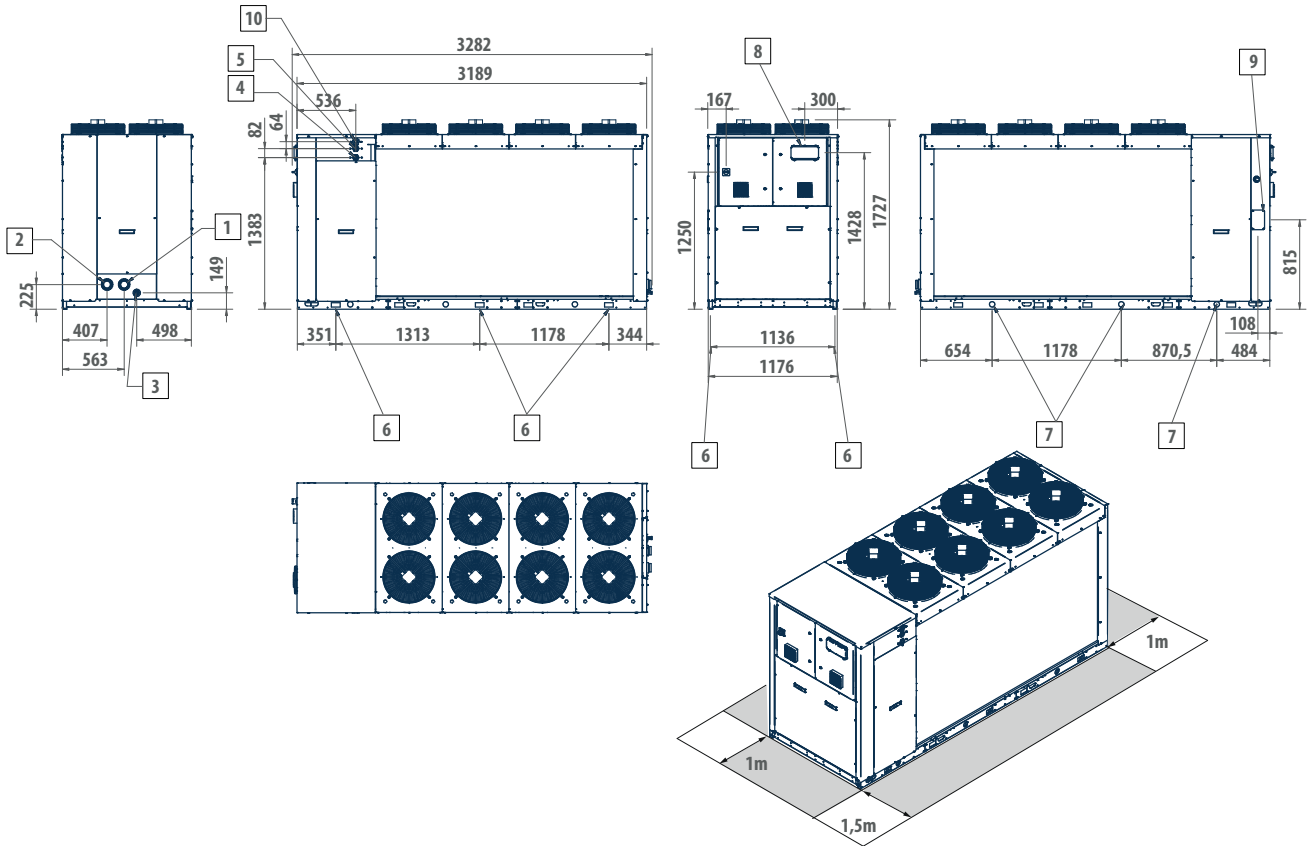

LEGEND

1	Water inlet Victaulic 2" 1/2
2	Water outlet Victaulic 2" 1/2
3	Water drainage 1/2" F
4	Heat exchanger inlet 1" 1/4 F
5	Heat exchanger outlet 1" 1/4 F
6	Vibration dampers
7	Lifting points
8	User interface
9	Power supply input
10	Outlet safety valve 1" 1/4 NPT